

CHAPTER 4

HIGHWAYS

4.01 NEW ROAD CONSTRUCTION:

(1) PURPOSE: Without limitation because of enumeration, the Town Board may:

(a) Notwithstanding Sec. 60.10(2)(e), Wis. Stats. acquire lands to lay, construct, alter, extend or repair any highway, street or alley in the Town.

(b) Provide for laying, constructing, altering, extending, replacing, removing or repairing any road, sanitary sewer, or storm sewer in the Town.

(c) Provide for lighting for roads, as defined under Sec. 340.01 (22), Wis. Stats. located in the Town.

(d) Provide for making improvements in any lake or waterway located in the Town.

(2) PAYMENT OF CONSTRUCTION EXPENSES: All expenses involved in the preparation, construction and dedication involved in road construction under this Chapter shall be borne by the applicant(s).

(3) PRELIMINARY INSPECTION: Prior to the design, preparation and construction of any roadway to be dedicated to the Town of Rome, the applicant shall notify the Town Superintendent of Highways. An on-site meeting will then be arranged to be attended by the Superintendent of Highways and the applicant. Plans must be provided in order for the Superintendent of Highways to check the design and the drainage.

(4) ROADWAY SPECIFICATIONS

(a) General Requirements:

1. Construction Standards: All roadway construction and materials used shall be performed in accordance with the construction methods as listed in the appropriate current sections of the "State of Wisconsin Department of Transportation Standard Specifications for Road and Bridge Construction: and its

supplements, or in accordance with Town approved plans, profiles and cross sections and specifications, if such specifications are requested by the Superintendent of Highways. No construction shall be started until the Superintendent of Highways has approved such plans, profiles and cross sections.

2. Project Costs: All roadway surveys, dedications, plans and specifications and construction will be at the expense of the applicant or applicants. This includes any expense incurred by the Town in the preparation of plans and review and inspection of plans and construction.

3. Material Slips: Copies of material slips for all materials furnished for the road construction projects shall be delivered to the Town before the Town approves the final construction.

4. Required Inspections: The contractor shall notify the Superintendent of Highways prior to the start of construction and when each stage of construction is ready for inspection. Inspections will be required at the completion of the following stages:

a. Sub base grading

b. Crushed aggregate course

c. Bituminous surface course; and

d. Shouldering

Any deficiencies found by the Town shall be corrected before proceeding to the next phase of construction.

5. Tests of Materials: The Town reserves the right to obtain a sample of the roadway base material prior to placement on the roadway for purposes of determining whether this material meets gradation and soundness requirements.

6. Pavement Samples: The Town will take samples of material during pavement construction operations for purposes of determining that the material meets specifications.

7. Town Approval: The finished roadway must meet the approval of the Town, since the Town

will include this roadwork in their annual request for highway aid.

(b) Construction Standards: All roads constructed in the Town shall fully comply with the following construction standards, with construction at the applicant's expense:

1. Topsoil Removal: All topsoil shall be first removed. In addition, all subsoil which have a high shrink-swell potential, low-bearing capacity when wet or are highly elastic shall be removed and used outside of the right-of-way. Where both subsoil and substratum have a high shrink-swell potential and low-bearing capacity when wet, an under drain system shall be installed to keep the water level five (5) feet below the pavement surface.

2. Right-of-way Width: A minimum road right-of-way width of sixty-six (66) feet is required.

3. Cul-de-sacs: Cul-de-sacs or dead ends shall have a two hundred (200) foot turnaround diameter.

4. Roadway Alignment Details: Roadway alignment shall be in the center of the road right-of-way.

5. Roadway Grading/Ditches: Roads shall be graded to their full width in accordance with approved plans, plus an additional distance necessary to establish a four-to-one back slope. The roadway shall be compacted and graded to sub-grade using, where necessary, approved fill material which has a low shrink-swell potential, low compressibility and is stable. Roadside ditches shall be a minimum of twenty-six (26) inches below the finished roadway centerline elevation. Debris may not be buried in the sixty-six (66) foot road right-of-way. Roadway ditches shall have a normal slope ratio of six (6) to one (1) ditch slope of 0.30 percent.

6. Roadway Grades: Roads shall have a maximum grade of eight percent (8%).

7. Roadway Width: Roadways shall have base width minimums of twenty-six (26) feet of full depth gravel. 100%-fractured rock shall be used for the base gravel. The Town officials may impose other provisions of gravel in low, wet or

sandy places where additional gravel or fill would be required for public health, safety and maintenance reasons.

8. Roadway Base Thickness: The roadway base thickness shall be a minimum of six (6) inches of compacted in-place 100% fractured rock.

9. Pavement Width: Roads shall have a minimum pavement width of twenty-two (22) feet or wider when required by the "Town Road Standards" as noted in Sec. 86.26, Wis. Stats. or by the Town Subdivision Ordinance, if applicable, the wider of which shall apply.

10. Pavement Thickness: The roadbed shall be paved with compressed bituminous hot mix pavement a minimum of two (2) inches thick compacted in place. The Town may require greater pavement thickness where traffic volumes and composition dictate the need.

11. Shoulder Width: A shoulder a minimum of two (2) feet wide on each side of the road is required and wider when required by the "Town Road Standards" as noted in Sec. 86.26, Wis. Stats.

12. Shoulder Thickness: Road shoulders shall have a minimum thickness of two and one-half (2-1/2) inches of compacted in-place crushed state-approved aggregate base course, over a minimum six (6) inches of compacted in-place crushed state-approved aggregate base course.

13. Roadway Culverts and Bridges: Surface Drainage: Roadway culverts and bridges shall be constructed as directed by the Town and sized utilizing the methods listed in the Chapter entitled "Drainage" of the "Facilities Development Manual" of the Wisconsin Department of Transportation. The developer shall provide adequate facilities to provide surface water drainage as well as free-flow outlets for subsurface drain tile where they are required. Where drainage facilities will aid in road construction and the stabilization of the road's subgrade, drainage facilities shall be installed before road construction is started.

14. Topsoil, Grass, Seed, Fertilizer and Mulch: All disturbed areas (ditches, back-

slopes) within the road right-of-way not provided with pavement and shouldering material shall be restored utilizing two (2) inches of topsoil and good-quality grass seed, fertilizer, and mulch. Ditches along the roadway with greater than a 2.5 percent slope shall be protected by erosion control materials such as hay bales, sod, erosion control mats, rip rap, etc.

15. Signs: All roads constructed in the Town of Rome shall have all street signs, stop signs, and other necessary signs installed by the subdivider, as determined by the Town or its donee, prior to dedication of the road.

16. Extra Turn Surface: All roads that come to an intersection shall have a turn radius of extra bituminous surfacing meeting other construction requirements for roads in this Section. (Such extra turn surface shall start thirty (30) feet before the intersection with the second road and extend to a point thirty (30) feet from the corner intersection on the other road.

17. Curvatures: Curvatures shall be between a six percent (6%) minimum and twelve and one-half percent (12-1/2%) maximum curve for a road curve rated at thirty-five (35) miles per hour, excluding cul-de-sacs.

18. Street Names: The Town and/or County may disapprove of the name of any road shown on the plat which has already been used elsewhere in the County, or which, because of similarity may cause confusion or otherwise be inconsistent with the road naming policy. Where a road maintains the same general direction, except for curvilinear changes for short distances, the same name shall continue for the entire length of the road. A name which is assigned to a road which is not presently a through road due to intervening land over which the road extension is planned, shall be continued for the separate portions of the planned through road. Approval of road names on a preliminary plat will not reserve a road name, nor shall it be mandatory for the Town to accept it at the time of the final platting.

(c) Statutory Requirements: The laying out of highways and roads shall be provided in Chapters 80 and 86, Wis. Stats. except that, in the case of subdivisions and certified surveys,

the provisions of Sec. 236.29(2), Wis. Stats., shall apply.

(d) Proximity to Other Roads: No road applied for running parallel with existing public road can be closer than six hundred (600) feet. Roads shall be laid out to provide for possible continuation wherever topographic and other physical conditions permit. Provision shall be made so all proposed streets shall have a direct connection with, or be continuous and in line with, existing, planned or platted road with which they are to connect. Proposed road shall be extended to the boundary lines of the tract to be subdivided, unless prevented by topography or other physical conditions, or unless in the opinion of the Town Board such extension is not necessary or desirable for the coordination of the layout of a subdivision with existing layout or the most advantageous future development of adjacent tracts.

(e) Dedication: The applicant shall provide the Town with a warranty deed for fee ownership of the road right-of-way and easements for all drainage facilities not within the road right-of-way. Where required, the applicant shall also furnish to the Town any special deed or easement, such as, but not limited to, sight easements, slope easements, pedestrian-ways, sewer easements and such.

(5) PERFORMANCE BOND: The applicant shall provide a bond, which would enable the Town to finish the road, in case of default by the applicants. The performance bond or cash escrow agreement shall be equal to the estimated cost of the required improvements. If the required improvements are not complete within the same, all amounts held under the escrow agreement or performance bond shall be turned over to the Town and applied to the cost of the required improvements. Any balance remaining after such improvements have been made shall be returned to the owner or subdivider. The Town Board, at its option, may extend the bond period for any additional period not to exceed one (1) year.

(6) FINAL INSPECTION: Upon completion of the proposed road, the Town Board will proceed to make final inspection, accepting or rejecting road as the case may be. After all of the

provisions of this Chapter have been complied with, the roadway or easement will be inspected by the Town officials and, at that time, proof will be made by the presenting of waivers of liens or receipted bills that all work that has been done has been paid for or arrangements have been made for the payment through written instrument by the subdivider. If the road is rejected, corrections shall be made as recommended by the Town Board before final inspection can then be made again. If final acceptance is then made, the owner or owners shall turn over to the Town the deed of all land necessary for the road as previously mentioned.

**4.02 ROAD RIGHT-OF-WAYS: (1)
ALTER-ATION/EXTENSION OR
ADDITION:**

(a) Regulations:

1. No person, partnership, utility or corporation, or their agents or employees or contractors shall make or cause alteration, extension or addition within the road right-of-ways without a permit issued by the Superintendent of Highways.

2. An application for the permit shall be submitted to the Superintendent of Highways with a written plan of the proposed alteration, extension or addition, showing its location and details of construction, including specified depth, method of auguring, provisions of restoration and whatever the Town would deem necessary for review and consideration. The Superintendent shall approve or deny a permit application within 60 days of receipt of the application. If a permit application is denied, the Superintendent shall provide the applicant with a written explanation of the reasons for denial.

3. No openings in the roads, sidewalks or public ways shall be permitted when the ground is frozen except where it is deemed necessary by the Superintendent of Highways.

4. In any opening or excavation, all paving or ballasting materials shall be removed with the least possible loss of or injury to surfacing materials and together with the excavated materials from the opening shall be placed so as to cause the least practicable inconvenience to

the public and permit free flow of water in the right-of-ways.

5. Every opening and excavation shall be enclosed with sufficient barriers. Sufficient warning lights shall be kept on from sunset to sunrise. Such lights shall be spaced so as to give adequate warning of the existence of the opening and piled excavated materials. No open flame warning pots shall be used. Except by special permission from the Town, no trench shall be excavated more than two hundred fifty (250) feet in advance of pipe or conduit neither laying nor left unfilled more than five hundred (500) feet where pipe or conduit has been laid. All necessary precautions shall be taken to guard the public effectively from accidents or damage to persons or property through the period of the work. Each person making such opening shall be held liable for all damages, including costs incurred by the Town in defending any action brought against it for damages, as well as cost of any appeal, that may result from the neglect by such person or his employees of any necessary precaution against injury or damage to persons, vehicles or property of any kind.

6. Unless the work shall be commenced within thirty (30) days from the date of approval, permission shall be void, and a new request must be submitted. The Town may extend the time limitation for good cause. The applicant shall have present at the site of construction and during the restoration period a copy of the construction plans and Town's written permission.

7. It shall be the duty of the permittee to notify the Superintendent of Highways and all private individuals, firms and corporations affected by the work to be done at least twenty-four (24) hours before such work is to commence. The Superintendent of Highways shall also be notified at least four (4) hours prior to backfilling and/or restoring the surface.

8. During the period of construction and excavation, the utility shall take all reasonable precaution, including following all industry standards, in protecting the safety of all persons, including but not limited to, area residents, motorists and Town employees, who are likely to be in the area of construction and/or excavation.

The utility shall also take reasonable precaution necessary to protect the environment and prevent erosion.

(b) Restoration:

1. All surface monuments or hubs must be removed and replaced as nearly as possible in their original condition or position. Any excavated material, which, in the opinion of the Town, is not suitable for refilling, shall be replaced with approved backfill material. All rubbish shall be immediately removed. In refilling the opening, the earth must be puddled or laid in layers not more than six (6) inches in depth and each layer rammed, tamped or flushed to prevent after-settling. When the sides of the trench will not stand perpendicular, sheathing and braces must be used to prevent caving. No timber, bracing, lagging, sheathing or other lumber shall be left in any trench. The Town may elect to have the opening repaired by the Town, in which case the cost of making such repair and of maintaining it for one (1) year shall be charged to the person making the road opening.

2. The person who does such restoration shall be responsible therefore for two (2) years from the date of the completion of the work and shall file a written guarantee or surety bond to that effect with the Town in the amount of One Thousand Dollars (\$1,000.00).

3. Whenever the Town shall find that any such work has become defective within two (2) years of the date of completion, it shall give written notice thereof to the contractor or to his surety stating the defect, the work to be done, the cost thereof and the period of time deemed by the Town to be reasonably necessary to complete said work. After receipt of such notice, the contractor or the surety must, within the time specified, repair the defect or indemnify the Town for the cost of doing the work as set forth in the notice.

(c) Insurance Required: Written permission shall be issued only upon condition that the applicant submit to the Town satisfactory written evidence that applicant has in force and will maintain during the time the permit is in effect public liability insurance of not less than One

Hundred Thousand Dollars (\$100,000.00) per one (1) person, Three Hundred Thousand Dollars (\$300,000.00) for one (1) accident and property damage coverage of not less than Fifty Thousand Dollars (\$50,000.00). The Town shall be listed as a third party insured on the policy.

(d) Bond: Before written permission is issued, the applicant must sign a statement that he will indemnify and hold harmless the Town of Rome and its officers from all liability for accidents and damage caused by any of the work covered by his permit, and that he will fill up and place in good and safe condition all excavations and openings made in the road, and will replace and restore the pavement over any opening he may make as near as can be to the state and condition in which he found it, and keep and maintain the same in such condition, normal wear and tear excepted, to the satisfaction of the Town Board for a period of two (2) years, and that he will pay all fines imposed upon him for any violation of any rule, regulation or ordinance governing road openings or drain laying adopted by the Town Board and will repair any damage done to existing improvements during the progress of the excavation in accordance with the ordinances, rules and regulations of the Town. Such statement shall also guarantee that if the Town shall elect to make the road repair, the person opening the road will pay all costs of making such repair and of maintaining the same for one (1) year.

(e) Costs to be paid by utility: Pursuant to PSC 130.05 (Wis. Admin. Code) and under the authority of the Town generally, a utility shall be required to pay the actual cost of functions undertaken by the Town to manage utility access to and use of municipal right-of-way. These management functions include all of the following:

1. Registering utilities, including the gathering and recording of information necessary to conduct business with a utility.

2. Issuing, processing and verifying excavation or other utility permit applications, including supplement applications.

3. Inspecting utility job sites and restoration projects.

4. Maintaining, supporting, protecting or moving utility equipment located within a municipal right-of-way during highway, street and right-of-way work undertaken by or at the direction of the Town. In lieu of payment of the actual cost, a utility may perform the duties.

5. Undertaking restoration work inadequately performed by a utility after providing notice and the opportunity to correct the work.

6. Revoking utility permits.

7. Maintenance of databases.

8. Scheduling and coordinating, when possible, highway, street and right-of-way work relevant to a utility permit.

In lieu of payment of the actual cost, a utility may perform the duties enumerated in paragraph (4) above.

(f) Permanent relocation of utility facilities: Pursuant to PSC 130.09 (Wis. Admin. Code) the Town may require a utility, at its expense, to permanently relocate transmission or distribution facilities in a municipal right-of-way when necessary for health, safety or public welfare.

(g) Abandonment: A utility shall notify the Town of the utility's intent to abandon transmission or distribution facilities and the utility shall provide the Town a map, at the utility's expense, depicting the location of any facility within the Town that the utility intends to abandon.

(h) Advance excavation work plans: A utility shall submit to the Town of Rom Public Works Director its future construction or excavation work plans in a time frame that will allow the Town to coordinate work within a municipal right-of-way.

(i) Definition: In this section, the definition of terms shall be as set for in PSC 130.01 (Wis. Admin. Code). Provided, however, the term utility as used in this section shall include an interim cable television operator and a video service provider.

(j) Exception: The provisions of this Section shall not apply to excavation work done by Town employees or contractors performing work under contract with the Town except that the safety precautions in this Chapter shall be complied with.

4.03 RIGHT-OF-WAYS:

(1) Removal of Fallen Trees: If any tree falls from adjacent land into any road right-of-way, the owner or occupant of the land shall immediately remove the tree from the road right-of-way. If the property owner following notice from the Town does not remove the tree, the Town may remove any fallen tree or trees therein and charge the cost thereof to the property owner pursuant to Sec. 66.0627, Wis. Stats. When it is necessary for trees in a road right-of-way to be removed, the adjacent property owner shall have a right of first refusal to have the wood. After receiving notice that a tree is to be removed, the adjacent property owner shall have fourteen (14) days to remove the tree.

(2) Fences, Misc. Items: It shall be unlawful for any person to build a fence or any item, or to throw, deposit or place any weeds, sod, brush, cans, glass, gravel, stones, boulders, machinery, garbage, other waste or rubbish or any item beyond the property lot stakes.

(3) Mailboxes: Rural mailboxes are prohibited on the right-of-way of all roads within the Town of Rome except as hereinafter provided:

(a) Mailboxes are approved only if they are of a construction or design approved by the United States Postal Service or previously approved by the Postmaster.

(b) Newspaper tubes are permitted only if provided by the newspaper.

(c) A nameplate bearing the name and address number of the mailbox owner shall be permitted on each box.

(d) The support for the mailbox and newspaper tube shall adhere to the standards governing construction of mailbox supports as established

by the Wisconsin Department of Transportation and shall not constitute a hazard to the public use of the right-of-way.

(e) Mailbox and newspaper tubes must be located on the side of the road required by the United States Postal Service. The door of the mailbox or protruding end of the newspaper tube should be even with the gravel on the ditch side or at least two (2) feet from the paved edge of the roadway.

(f) No other object of any kind shall be attached to the mailbox, newspaper tube or their supports. No other objects, including, but not limited to, landscaping boulders or fences may be placed on the right-of-way.

(g) This Section is not intended to and shall not be construed to create any affirmative duty on the part of the Town of Rome to locate and remove obstructing mailboxes.

(h) The Town of Rome is not liable for damage to mailboxes caused by snowplowing. Provided, however, that if in the sole discretion of the Highway Superintendent or his designee a mailbox is damaged as a result of a direct hit by a Town vehicle or equipment, the Highway Superintendent may authorize the Town Highway Department to repair or replace such damage. The owner of the mailbox must first apply for such relief. The Town shall not repair or replace a mailbox damaged by snow that has been plowed or pushed.

(4) Temporary Signs: Certain temporary signs will be allowed in the road right of way with the following provisions:

a. Shall be placed no closer than ten (10) feet from the edge of the road surface.

b. No larger than two (2) foot by (2) feet, four (4) square feet total.

c. No higher than four (4) feet above existing established adjacent grade to the top of the sign.

d. Time of placement and removal.

1. Civic signs may be placed only fourteen (14) days prior to the event and removed within twenty-four (24) hours after the event.

2. Rummage sale, garage sale, open house and directional signs for the event may be placed only two (2) days prior to the event and removed within twenty-four (24) hours after the event. Examples: family events; estate; garage and rummage; directional signs, as needed for the event.

3. Each sign will contain the name and phone number of the person who owns the sign.

4. A civic event is any organized occasion relating to a community. Examples: business, associations, teams, etc. in which they may sponsor or organize an activity.

5. Political signs may be placed seven (7) days prior to the primary election and fourteen (14) days prior to the general election and removed within twenty-four (24) hours after the election. This provision is adopted in an effort to ensure traffic safety.

(6) Obstruction of Intersection: No person shall maintain, plant or permit to remain on any private or public premises situated at the intersection of two (2) or more roads, in the Town any hedge, tree, shrub or other growth, which may obstruct the view of the operator of any motor vehicle or pedestrian approaching such inter-section.

(7) Obstruction of Signs: It is unlawful for any person to plant, cause to grow, allow to grow or maintain any trees, bushes, shrubbery or vegetation of any kind, which is an obstruction to the clear and complete vision of any traffic sign in the Town. It shall be the duty of every owner of such tree, brush, shrubbery or vegetation to remove such obstruction.

(8) Abatement Procedure: Any shrub, tree or other plant which obstructs the view at an intersection or the view of a traffic sign shall be deemed to be dangerous to public travel, and the Town shall notify the property owner in writing, describing the conditions, stating the steps necessary to correct the conditions, and establishing a reasonable time within which the corrective steps shall be taken. In the event that effective steps are not taken within the time specified it shall be lawful for the Town to abate

these conditions to the extent necessary to assure compliance with the foregoing requirements, and the costs thereof shall be assessed to the owner.

(9) Driveways: Any person installing a driveway shall, prior to any such installation, obtain an installation permit from the Superintendent of Highways. Application for a permit to construct a driveway shall be made in writing to the Superintendent of Highways and shall describe the property and the road or street where the driveway will be constructed. All driveways installed, altered, changed, replaced or extended after the effective date of this chapter shall meet the following requirements and must be approved as to location by the Superintendent of Highways/Public Works.

a. The maximum number of driveway openings for vehicular ingress and egress permitted for lots with a width less than one hundred (100) feet shall be one (1) and for lots with a width greater than one hundred (100) feet, two (2) driveway openings may be permitted with approval of the Superintendent of Highways.

b. Vehicular entrances and exits to any business, industry or public lots shall be not less than two hundred (200) feet from any pedestrian entrance or exit to a church, park, playground, library, public emergency shelter, or other place of public assembly.

c. At the property line driveways shall be a maximum of thirty (30) feet wide and a minimum of ten (10) feet wide.

d. Openings for vehicular ingress and egress shall be a maximum of forty (40) feet wide and a minimum of fifteen (15) feet wide. The maximum curb and gutter opening for all residential districts shall be twenty-five (25) feet.

e. The surface of the driveway connecting with the roadway shall slope down and away from the road shoulder a sufficient amount and distance to preclude ordinary surface water drainage from the driveway area flowing onto the roadbed. The driveway shall not obstruct or impair drainage in the roadside and ditch areas. The surface shall be no less than a road base

grade of material. The use of ditches for a driveway is not permitted.

f. If a concrete driveway is installed in the right-of-way, a fiber expansion joint must be installed at the property line. If the concrete driveway must be removed from within the right-of-way for roadway work, the property owner will be financially responsible for removal and replacement.

g. When the Town determines a culvert is necessary for proper water control, the Town will determine the size, material of the culvert and end walls.

h. The Superintendent of Highways may grant temporary access to the road right-of-ways. Such access permit shall be temporary, revocable and subject to any conditions required and shall be issued for a period not to exceed twelve (12) months.

i. Any repairs or cleaning of the roads adjacent to the installation of driveways shall be at the owner's expense. The owner may contract for the service or the Town of Rome may repair at its' discretion.

j. A plot plan showing the placement of the driveway access shall be required along with the permit.

k. Any private driveway leading to a building or structure located 200 feet or more from the public right-of-way shall be at least 18 feet in width; shall provide an unobstructed height throughout the entire length and width of the driveway of at least 14 feet, and shall have a cul-de-sac or turn around at or near the end of the driveway with a minimum right-of-way radius of 50 feet. Greater dimensions may be required by the Superintendent of Highways if the cul-de-sac or turn around would not be sufficient so as to accommodate fire fighting vehicle, apparatus and equipment that might be required to serve the property.

(10) Traffic Visibility:

a. Clear Vision Areas: All Town highway intersections in the Town of Rome shall be provided with a clear vision area, triangular in

shape, bounded by the highway center lines and a line connecting the centerline points at a specified distance from their point of intersection.

b. Centerline Defined: Centerline shall be defined as follows:

1. Where there is an undivided pavement within a right-of-way, the centerline shall be the centerline of that pavement, irrespective of whether or not that coincides with the centerline of the right-of-way.

2. Where there is a divided pavement within a right-of-way, the centerline shall be the centerline of the median strip between the pavements, except as specified in Subsection below.

3. Where there is a divided pavement within a right-of-way and the distance between the center lines of the pavements, measured along the centerline of the intersecting Town highway is sixty (60) feet or greater, the centerline of the pavements shall be used separately in the manner illustrated in Figure 1, to designate the clear vision triangles.

4. Clear Vision Triangle Sizing: The distance from the point of intersection of the centerlines of two (2) Town highways to the points on those centerlines that are to be used to determine visual clearance triangle size shall be as follows:

- Town Highways in speed zones
25 MPH or less - 45 feet
- Town Highways in speed zones
greater than 25 MPH but less than or equal to
45 MPH - 75 feet
- Town Highways in speed zones
greater than 45 MPH - 100 feet

(11) (a) Brushing or trimming operations in a right of way which are not necessary to prevent trees or brush from directly threatening or impeding the safe flow of traffic along any traveled portion of any Town road shall be conducted in the following manner :

1. In the fall of each year, the Superintendent of Highway and Public works shall submit a plan to the Town Board that lists the roads on which it is

proposed that brushing or trimming operations will be performed together with the reasons in support of such brushing and trimming. Such reasons may include the need to establish a clear zone; establish or improve vision triangles; improve vision at curves; improve cul-de-sacs, or to maintain the integrity of any Town road infrastructure including drainage areas, ditches or slopes.

2. The Town Board shall review the plan and, if necessary, go on-site to view the proposed plan. After the Town Board approves said plan, subject to any modifications, it will be posted at the Rome Town Hall and all Town posting locations. The Public Works Director shall also send written notice to the affected landowner(s) at least ten days prior to commencement of the brushing or trimming operations.

(b) The Public Works Director is authorized to conduct mowing and trimming operation within the right of way of a town road as determined necessary for traffic safety purposes.

4.04 SNOW REMOVAL IN PRIVATE DRIVEWAYS:

(1) The Town may remove snow from private driveways and roads, if approved by the Town Board.

(2) The Town of Rome assumes no responsibility for damage to property while plowing private driveways.

(3) Private drives will not be sanded or have salt applied by the Town.

4.05 MOVING BUILDINGS: (1) MOVING BUILDINGS:

(a) General Requirements:

1. No person shall move any building or structure upon any of the public roads of the Town without first obtaining written permission therefore from the Superintendent of Highways. The Superintendent of Highways shall designate the route to be taken, the conditions to be complied with and shall limit the time during which said moving operations shall be continued.

2. The Town shall make a report with regard to possible damage to trees. The estimated cost of trimming, removal and replacement of public trees, as determined by the Town, shall be paid to the Town Treasurer prior to written approval.

(b) Continuous Movement: The movement of buildings shall be a continuous operation during all the hours of the day and at night, until such movement is fully completed. All such operations shall be performed with the least possible obstruction to thoroughfares. No building shall be allowed to remain overnight upon any road. Lights shall be kept in conspicuous places at each end of the building during the night.

(c) Bond: Before permission is issued to move any building over any road in the Town, the party applying therefore shall give a bond to the Town in a sum to be fixed by the Superintendent of Highways which shall not be less than Five Thousand Dollars (\$5,000), said bond to be executed by a corporate surety or two (2) personal sureties to be approved by the Town Board conditioned upon, among other things, the indemnification to the Town for any costs or expenses incurred by it in connection with any claims for damages to any persons or property, and the payment of any judgment together with the costs and expenses incurred by the Town in connection therewith arising out of the removal of the building for which approval is issued.

(d) Insurance: The Superintendent of Highways shall require, in addition to the said bond above indicated, public liability insurance covering injury to one (1) person in the sum of not less than One Hundred Thousand Dollars (\$100,000) and for one (1) accident in a sum not less than Two Hundred Thousand Dollars (\$200,000), together with property damage insurance in a sum not less than Fifty Thousand Dollars (\$50,000.00), or such other coverage as deemed necessary.

(e) Street Repair: Every person receiving approval to move a building shall, within one (1) day after said building reaches its destination, report that fact to the Superintendent of Highways, to inspect the roads over which said building was moved. If

the moving of said building has caused any damage to any road, the person to whom the approval was issued shall forthwith place them in as good repair as they were before approval was granted. Failure of the mover to do so within ten (10) days to the satisfaction of the Superintendent of Highways, the Town shall repair the damage done to such roads and hold the person obtaining such permit and the sureties on his bond responsible for the payment of same.

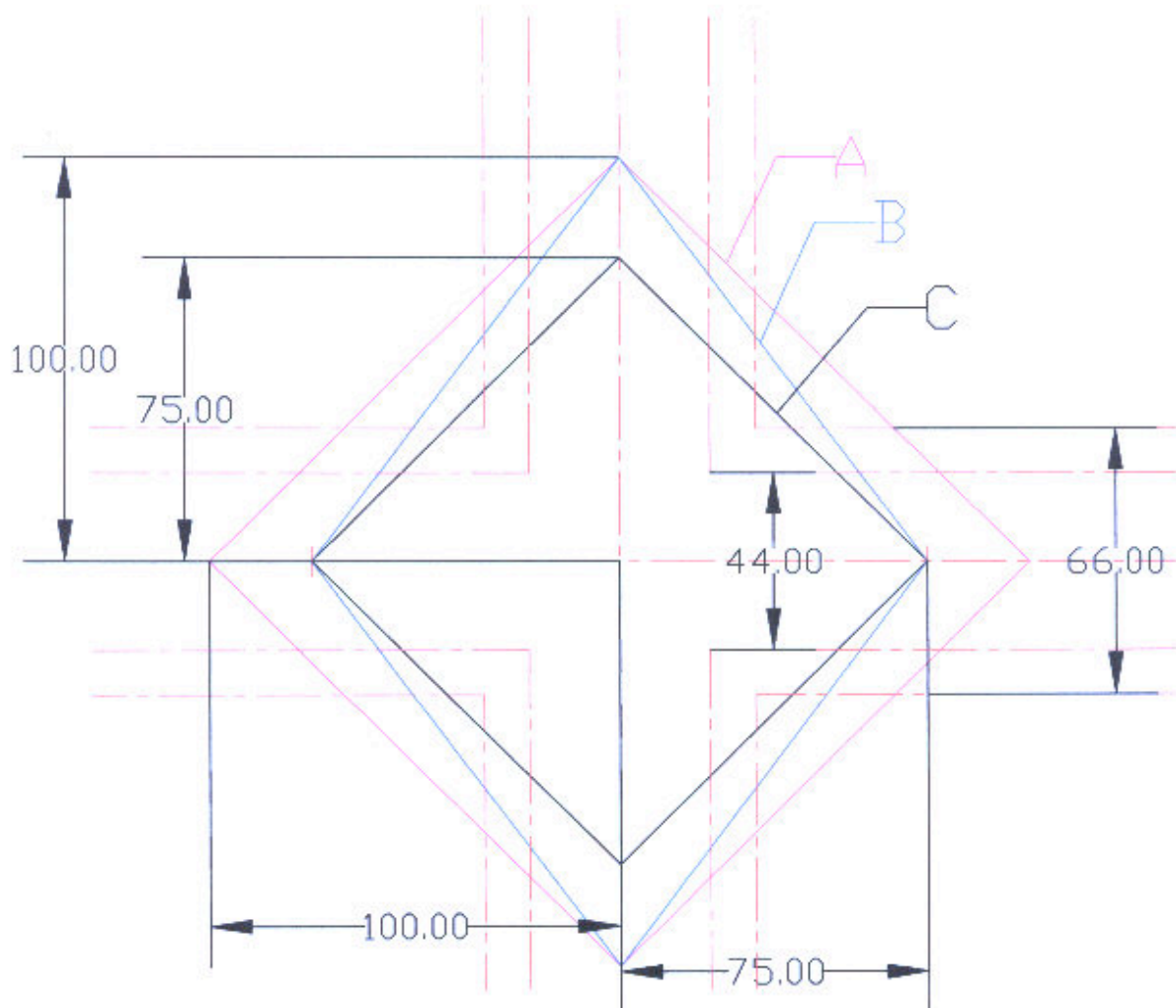

CLEAR SIGHT TRIANGLES

- A Greater than 45 MPH in both directions.
- B Greater than 55 MPH intersecting with a less than 45 MPH road.
- C Less than 45 MPH in both directions.

